



DynAmp

LKAT² OEM EMC

BI-DIRECTIONAL HIGH CURRENT MEASUREMENT SYSTEM with RECTIFIER PROTECTION FUNCTION

Installation, Operation and Service Manual

Manual Item No. 047103

Rev. New



This Page is Intentionally Blank

DYNAMP, LLC WARRANTY

Items and components manufactured by DynAmp, LLC for permanent installation are warranted to be free from defects in material and workmanship for a period of two (2) years from the date of shipment.

Items and components manufactured by DynAmp, LLC for portable and temporary use in more than one location are warranted to be free from defects in material and workmanship for a period of eighteen (18) months from the date of shipment.

Extended warranties may be available for purchase for some products. Extended warranties are provided on a serial number by serial number basis as noted on DynAmp's original invoice and/or packing list.

Items and components not manufactured and resold by DynAmp, LLC are warranted by their manufacturer.

Warranty repair shall be, at DynAmp's option, in the form of repair or replacement of the defective items or components. Concerning warranty repairs, DynAmp, LLC will be responsible for DynAmp provided time, material and transportation costs (shipping or travel). Actual method of warranty repair / correction will be determined by DynAmp, LLC at DynAmp's sole option. Such warranty repair shall constitute a fulfillment of all DynAmp, LLC liabilities in respect to said items and components. In no event shall DynAmp, LLC be liable for consequential damages.

Information in this document is subject to change without notice.

© 2015, 2016, 2018, 2019, 2020, 2021, 2022 DynAmp, LLC. All rights reserved.

Reproduction in any manner whatsoever for purposes other than installation, operation, or service by the purchaser or end user without the written permission of DynAmp, LLC is strictly forbidden.

This manual is part of the complete set of product documentation that includes installation, operation, and service instructions, drawings and test results. Users should evaluate the information in the context of the complete set of product documentation and their particular applications. DynAmp, LLC assumes no liability for any incidental, indirect, or consequential damages arising from the use of this documentation.

While all information presented is believed to be reliable and in accordance with accepted engineering practices, DynAmp, LLC makes no warranties as to the completeness of the information.

All trademarks used in association with LKAT² are trademarks of DynAmp, LLC.

This Page is Intentionally Blank

The LKAT² Bi-Directional High Current Measurement System may be used with or without the optional Protection Extensions (“PE”) and / or RMS Display PC board assemblies. All configurations of the LKAT² System conform to the latest European directives and standards concerning safety and electromagnetic compatibility.

Application of Council Directive(s):

73/23/EEC, 89/336/EEC and 93/68/EEC.

Standards to which conformity is declared:

Electromagnetic Compatibility: Immunity (61000 - 6-2; 4-2, 4-3, 4-4, 4-5, 4-6, 4-8, 4-11)
Emissions (61000 - 6-3; 3-2, 3-3)

Safety Standards:

EN 61010-1: Safety Requirements for Electrical Equipment for Measurement, Control, and Laboratory Use.

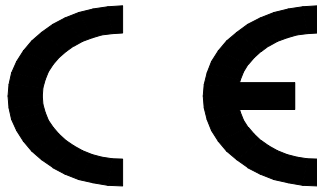

Note :

According to EN 50082, the manufacturer must state the degradation of performance level acceptable during immunity tests. Unless otherwise noted in the manual or data sheet, DynAmp limits degradation during immunity tests for this equipment to -0% FS < +3.7% FS for A-criterion tests.

This Page is Intentionally Blank

TABLE OF CONTENTS

<u>Paragraph</u>	<u>Title</u>	<u>Page</u>
	DYNAMP, LLC WARRANTY.....	III
	TABLE OF CONTENTS	VII
	HAZARD WARNING!	IX
	SAFETY	XI
	DYNAMP, LLC CUSTOMER SUPPORT & SERVICE ASSISTANCE	XIII
	MANUAL REVISIONS.....	XV
1.	HANDLING AND STORAGE	1
2.	PRODUCT DESCRIPTION.....	3
2.1	SYSTEM OVERVIEW.....	3
2.2	ADDITIONAL MEASURING HEAD DETAIL.....	6
2.3	ADDITIONAL METERING UNIT DETAIL	6
2.4	ADDITIONAL INDICATOR AND OUTPUT DETAIL	7
2.5	INTERCONNECTION CABLE DETAIL	7
3.	SPECIFICATIONS.....	9
4.	INSTALLATION.....	13
4.1	HANDLING PRECAUTIONS	13
4.2	INSTALLATION CONSIDERATIONS.....	13
4.3	OFF-BUS FUNCTIONAL CHECK (Optional).....	14
4.4	MEASURING HEAD INSTALLATION	14
4.5	METERING UNIT INSTALLATION.....	16
4.6	SYSTEM CHECKOUT	17
5.	THEORY OF OPERATION.....	21
5.1	GENERAL.....	21
5.2	OLOP TECHNOLOGY.....	21
5.3	SYSTEM FUNCTIONAL DESCRIPTION	22
5.4	LKAT ² METERING UNIT	23
5.5	LKAT ² MEASURING HEAD INTERCHANGEABILITY	23
5.6	TROUBLESHOOTING AN ACCURACY DIAGNOSTICS FAULT INDICATION	23
5.7	SYSTEM CALIBRATION OVERVIEW.....	24
5.8	CALIBRATION ADJUSTMENTS	26
5.9	FIELD CONFIGURATION OF TRIP SETPOINTS.....	28
5.10	EARTH GROUNDING	29
5.11	CONFIGURING THE LOW PASS FILTER.....	29
5.12	“FAILSAFE” / “NON-FAILSAFE” CONFIGURATION	30
6.	MAINTENANCE & SPARE PARTS	31
6.1	PERIODIC MAINTENANCE	31
6.2	ANNUAL MAINTENANCE	31
6.3	SPARE PARTS.....	32
7.	DRAWINGS	33

FIGURES, FORMS & TABLES

Figure # Title.....	Page
Figure 3.1 LKAT ² Frequency Response.....	11
Figure 4.1 Installation Configuration.....	15
Form 1 LKAT ² Diagnostic Measurements Form – Zero Primary Current.....	18
Form 2 LKAT ² Diagnostic Measurements Form – Energized Primary Bus.....	19
Figure 5.1 Block Diagram of the LKAT ² System.....	22
Table 2.1 Main and PE PC Board Assembly Features	7
Table 3.1 LKAT ² OEM EMC System Specifications (subject to change without notice)	9
Table 5.1 Troubleshooting an Accuracy Diagnostics Fault Indication.....	24
Table 5.2 Trip Configuration Details	28
Table 5.3 LKAT ² Alarm Relay Status	30
Table 6.1 Spare Parts List	32
Table 7.1 Drawing List.....	33

HAZARD WARNING!



GENERAL

All installation, maintenance and service must be performed by qualified technicians who are familiar with the warnings and instructions of this manual.

Use of the equipment in a manner not specified by the manufacturer can impair the protection provided within.

The enclosure cover must remain closed and secured with captive screws at all times during operation to ensure safety of personnel. The cover may be opened using a screwdriver; however, only authorized personnel or technicians should be allowed to open and service the unit.

Disconnect power to the system before servicing.

DynAmp, LLC does not assume liability for the customer's failure to comply with the rules and requirements provided in this manual.



HAZARDOUS VOLTAGE

This equipment is designed to be connected to hazardous electric voltages. Ignoring the installation precautions and warnings can result in severe personal injury or equipment damage.

To avoid the risk of electrical shock or fire, the safety instructions and guidelines in this manual must be followed. The electrical specifications must not be exceeded and the unit must be installed according to directions provided.



INSTALLATION

This equipment is intended for indoor or outdoor use. It should be mounted in a well-ventilated area, away from high heat, dust, and corrosive atmosphere. The ambient temperature must not exceed specified limits.

For mounting considerations that fall outside the recommended specifications provided in this manual, the factory should be contacted for approval.

This unit is rated for installation category II and pollution degree 2.

Symbol Identification:

General definitions of safety symbols used on equipment and manual.



Caution/Warning: Refer to accompanying documents for instructions.

This Page is Intentionally Blank

SAFETY

The Measuring Head is designed to be installed on high voltage bus bars. All interconnection cables must be safely routed away from bus bars and high voltages. Do not allow any interconnection cable to contact bus bars or high voltages.

Ignoring the installation precautions and warnings can result in severe personal injury or equipment damage. The following are general guidelines to be followed during installation, operation and service of the Metering Unit and Measuring Head.

- All installation, maintenance and service must be performed by qualified technicians who are familiar with the warnings and instructions of this manual.
- Always follow all local and plant safety procedures.
- The enclosure cover must remain closed at all times during operation to ensure safety of personnel. Only authorized personnel or technicians should be allowed to open and service the unit.
- Units are not intrinsically safe. Do not place in explosive atmospheres.
- Service must be performed by qualified technicians only. If use of an oscilloscope becomes necessary during servicing, the scope must be floating and ungrounded or differential probe(s) must be used. The Metering Unit is isolated from the mains via the power transformers. If a grounded scope is used, a hazardous condition is created since current will flow through the probe to ground.
- Use of the equipment in a manner not specified by the manufacturer can impair the protection provided within.
- If a binding screw is used for the mains earth connection, the binding screw must be size M4 (No. 6) or larger.

DynAmp, LLC does not assume liability for the customer's failure to comply with the rules and requirements provided in this manual.

This Page is Intentionally Blank

DYNAMP, LLC CUSTOMER SUPPORT & SERVICE ASSISTANCE

For further assistance, contact DynAmp, LLC Customer Support at:

Americas:

Telephone: +1 614.871.6900 Fax: +1 614.871.6910
8:00 AM to 5:00 PM USA Eastern Time
From first Sunday in November to second Sunday in March – 13:00 GMT to 22:00 GMT
From second Sunday in March to first Sunday in November – 12:00 GMT to 21:00 GMT

After Hours Critical Service Emergency:

Telephone: +1 614.871.6906
5:00 PM to 8:00 AM USA Eastern Time
From first Sunday in November to second Sunday in March – 22:00 GMT to 13:00 GMT
From second Sunday in March to first Sunday in November – 21:00 GMT to 12:00 GMT

Central e-mail:

help@dynamp.com

DynAmp web:

www.dynamp.com

This Page is Intentionally Blank

MANUAL REVISIONS

<u>Page</u>	<u>Change</u>	<u>Reason For Revision</u>	<u>Date</u>
all	NEW		11/22

This Page is Intentionally Blank

1. HANDLING AND STORAGE

DynAmp products are engineered and manufactured for use in industrial environments. However, they contain sensitive electronic and mechanical components which may be damaged and fail if not handled and stored properly. All products must be handled and stored with the same care as any precision measurement instrument. Severe bumps or jolts may damage internal parts and cause malfunction or premature failure. DynAmp products are designed and assembled with conformal coating, shock mounting, and environmental seals, when appropriate or when specified. However, this protection requires that the product must be properly installed and operational before the protection is fully functional. Therefore, adequate protection from humidity, shock, and temperature must be provided during handling and storage prior to installation.

The handling and storage of equipment must be sufficient to meet the storage temperature and humidity specifications of the product and to prevent any condensation or contact with water or any other liquid. The storage location and container or crate must provide adequate protection from precipitation (rain, snow, ice) and direct water contact. Adequate shelter must be provided to prevent the accumulation of precipitation (rain, snow, ice) and water which can lead to the deterioration or failure of shipping containers or crates and cause water ingress. Storage in coastal or industrial areas subject to salt-laden or corrosive air or areas of wind-driven sand or other abrasive dust must be adequate to prevent the deterioration or failure of shipping containers or crates and cause ingress. Frequent inspection of storage areas and storage containers or crates is required to ensure proper storage conditions are being maintained.

If the shipping container or crate is opened and/or the equipment is removed for inspection prior to installation, the equipment must be repackaged in the original undamaged container or crate in the same manner as it was shipped to prevent environmental damage or placed in a storage location that meets the required environmental and storage conditions.

General product storage temperature and humidity requirements:

Storage Temperature:	-40° to 70°C
	-40° to 158°F
Storage Humidity:	Maximum 85%, non-condensing

DynAmp, LLC does not assume liability for the customer's failure to comply with handling and storage requirements.

For further assistance, contact DynAmp, LLC customer support.

This Page is Intentionally Blank

2. PRODUCT DESCRIPTION

2.1 SYSTEM OVERVIEW

The LKAT² combines accurate high current measurement with reverse and overcurrent protection in a single rugged and cost effective system.

The next generation of DynAmp's well proven OLOP™ technology, LKAT² offers a new level of accuracy and stability to accurately and reliably measure uni- and bi-directional DC as well as AC bus currents.

The LKAT² is particularly well suited to measure power rectifier outputs for control and protection purposes in electro-chemical processes such as aluminum, chlorine, copper, manganese, titanium, zinc, electroplating, etc.

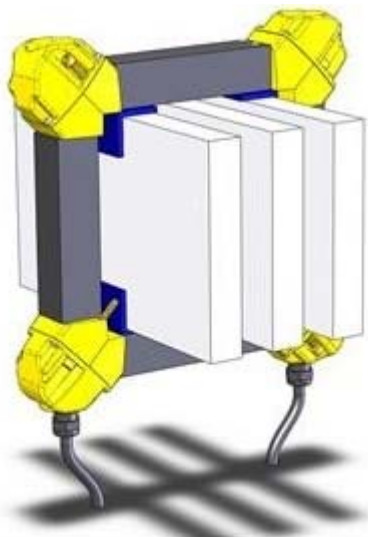

LKAT² Measuring Head

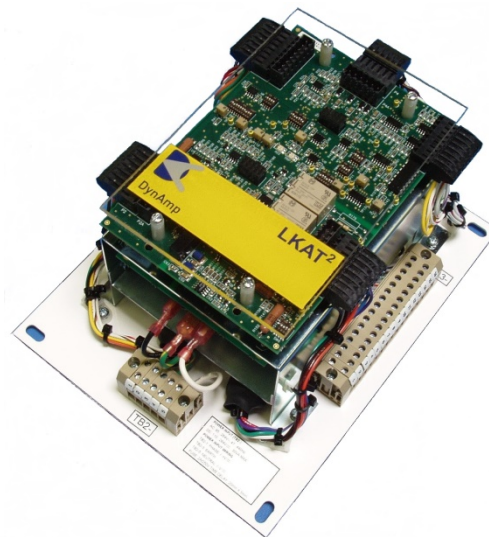

LKAT² OEM EMC Metering Unit

KEY STANDARD FEATURES

True bi-directional performance. Ideal for difficult magnetic applications. No Measuring Head position or bus analysis needed.

Extremely compact with excellent environmental specifications for installation flexibility, inside or outside.

Multiple, standard switch selectable measurement output signals including mA, mV and V.

Standard Accuracy Diagnostics "AD" continuously monitors system performance providing both local LED and relay contact output.

Optional LKAT² Protection Extensions, (PE), provides additional functionality for protecting high current rectifiers.

Standard Alarm provides reverse or over-current protection via an LED viewable at the metering electronics and a dry contact relay output.

Each standard LKAT² is delivered with the following:

- A new, ruggedized two-piece Measuring Head with integrated mounting hardware and bus bar corner (fiberglass angles). Each Measuring Head half has its own cable for connection to the metering electronics.
- Very compact Metering Electronics with one analog measurement output, one Accuracy Diagnostics system status output and one configurable Alarm output for overcurrent or reverse current protection. The LKAT² Metering Unit consists of a power supply pc board and Main pc board mounted together on a steel U-chassis. Input, output, and power connections are made via pc board edge connector plugs.
- System output cable
- Power input cable
- Comprehensive User's Manual
- Factory calibration data and graphs
- 2-year warranty for permanent installed systems
- Packaging suitable for air /ground transport

AVAILABLE OPTIONS

- **Protection Extensions (PE)**

The PE option adds additional functionality for protecting high current rectifiers. This option is either factory configured with a new system or can be added to LKAT² Systems already in the field. If added in the field, some field configuration may be required.

- **Second Freely Scalable Analog Output :**

This second analog output is independently scaled and fully isolated from the standard LKAT² measurement output. In typical applications, it is scaled to provide accurate measurement above the standard rectifier operating range for advanced protection purposes. For example, the primary LKAT² output may be scaled to 50kA to provide the highest degree of accuracy and resolution for normal rectifier control. The second PE output may be scaled to 75kA to provide the information to intelligently manage overcurrent situations. Using this signal, the rectifier control system could integrate overcurrent operation to allow 5 minutes at 110%, 1 minute at 120%, 10 sec at 140%.

- **Two Additional Protection Relays :**

These relays bring the total number of configurable relays to three. Each can be configured to provide reverse or various degrees of overcurrent protection. Like the standard alarm, these two additional PE alarms come with their own, independent local LED indication and relay outputs.

- **Digital current display (3 1/2 digit)**

This option is mounted behind the clear front door of the metering electronics enclosure to display either DC or RMS AC bus current locally. Please note that this option reduces the maximum metering electronics ambient temperature to 50°C. This option can also be added to LKAT² Systems already in the field.

- **Custom Cable Lengths**

Custom Measuring Head cable lengths can be provided but only at time of order. Note that Measuring Head cable lengths can be changed in the field.

Custom Signal and Mains cables lengths can be provided. Note that standard Signal and Mains cables can be shortened or replaced with longer cables in the field.

- **Optional low voltage DC mains**

This allows system to be powered by safety mains supplies or even batteries. This option must be specified at time of order and cannot be field retrofitted to existing units.

AVAILABLE ACCESSORIES

- **Summing / Totalizing multiple LKAT systems**

A dedicated external module is available for totalizing/ summing up to 10 LKAT measurement signals. This is typically used to provide a true 'total' current signal when multiple rectifiers (with individual LKAT systems) are connected in parallel to provide a higher total current.

- **LKAT Metering Unit Tester (LKAT MUT)**

The LKAT MUT is a portable tester used to verify the functionality of Metering Units for all versions of the LKAT family of products.

Adapters included with the LKAT MUT allow the tester to be connected directly and check any LKAT Metering Unit electronics.

The functions and parameters checked by the LKAT MUT include:

- Input / output sensitivity
- Trip point scaling
- Trip relay contacts
- Integrity of input / output harnesses and interconnections on Metering Unit

The tools / documentation required to use the LKAT Metering Unit Tester include :

- 4-1/2 digit DMM with 0.05% basic DC accuracy (user provided)
- DMM Test probes (user provided)
- Banana to banana cables (1black / 1 red)
- LKAT MUT Product Manual

More information on the LKAT MUT can be found at www.dynamp.com or by contacting DynAmp.



- **Extended Warranty**

For permanently installed systems, the standard 2-year warranty can be extended in 2-year increments. This must be ordered less than 6 months after the original LKAT system is shipped.

2.2 ADDITIONAL MEASURING HEAD DETAIL

LKAT² Measuring Heads contain an arrangement of Hall Effect sensor ICs and signal conditioning electronics. The tubular enclosure is constructed of flame retardant plastic with an internal aluminum frame. Insulation from the bus is provided by the homogeneous (sealed) construction of the Measuring Head. In the event that the Measuring Head enclosure components become cracked, the bonding fails, or the weather-tight seal is broken in any way, a replacement Measuring Head must be substituted. The Measuring Head is not designed to be repaired.

LKAT² Measuring Heads may be mounted on the bus bar using fiberglass angles positioned on the corners of the bus bar and stainless steel bus bar mounting screws threaded into the Measuring Head structure. Mounting hardware is supplied with each system. These screws are adjusted to bus dimensions specified with each order. When properly installed, the mounting hardware maintains the position of the Measuring Head in the event of temperature fluctuation and / or bus vibration.

An interconnection cable assembly is integral to each half of the Measuring Head. Measuring Heads with extra-long interconnection cables are also available - consult the factory for details. Standard Measuring Head cable assemblies are terminated with individual wires with crimp-on ferrules. Each wire is marked with a number to ensure correct hookup. The interconnection cables from the Measuring Head are identified as "A" and "B". Connecting Measuring Head cable "A" to Metering Unit "B" will not result in damage to the Measuring Head or electronics, but may degrade the calibration accuracy of the system.

2.3 ADDITIONAL METERING UNIT DETAIL

The LKAT² OEM EMC Metering Unit is supplied without an enclosure. The Plexiglas pc board cover must be installed during normal operation.

The main pc board assembly includes receptacles for external connection to the Measuring Head, the Metering Unit measurement signal(s) and relay outputs.

Internally, all LKAT² Metering Units include both a Power Supply pc board and a Main pc board. These pc boards are mounted to a steel chassis which is then mounted on a steel panel. The Metering Unit pc board cover allows the user to view various LED (or LCD) status indicators. For more information, refer to the "Theory of Operation" section of this manual.

There are two optional pc board assemblies that may be added onto the Main pc board in the LKAT² Metering Unit:

- The Protection Extensions (PE) pc board assembly
- The Display pc board assembly.

One or both of these pc board assemblies may be added to an LKAT² Metering Unit in the field. It is not mandatory that they be factory installed and/or calibrated. The optional pc board assemblies may be calibrated on site, using the LKAT² Main Output as the reference measurement.

2.4 ADDITIONAL INDICATOR AND OUTPUT DETAIL

As noted on the specifications page, the LKAT² System Metering Unit includes several visual indicators. These include:

- Accuracy Diagnostics (operational status) LEDs: green = OK, red = system problem (see Section - “Theory of Operation”).
- Over / Reverse Current Trip status LEDs: green = measured current does not exceed the setpoint, red = measured current exceeds the setpoint.
- (Optional) Illuminated LCD digital display of measured current.

Available via the Metering Unit output cable:

- Isolated signal output proportional to bus current being measured. This output may be configured for various zero and full-scale values.
- Normally open and normally closed relay contacts indicate Accuracy Diagnostics (AD) operational status (same as green and red LEDs).
- Normally open and normally closed relay contacts indicate over / reverse current trip status (same as green and red LEDs). For failsafe operation, the relay coil is energized in the normal condition (no over or reverse trip).

The table below lists the features associated with the Main and PE pc board assemblies.

**Table 2.1
Main and PE PC Board Assembly Features**

	Main PC Board Assembly	with PE PC Board Assembly
Isolated Output	1	+1 for 2 total
Operational Status LEDs & Relay Contacts	1	+0 for 1 total
Overcurrent / Reverse Trip Status LEDs & Relay Contacts	1	+2 for 3 total

Checking field calibration of LKAT² Systems requires use of a reference current transducer with calibration accuracy of 0.1% full-scale or better. Contact DynAmp, LLC for calibration of the LKAT² System. Refer to “Maintenance and Spare Parts” section for more information.

2.5 INTERCONNECTION CABLE DETAIL

The LKAT² OEM EMC System is not supplied with cable assemblies for power input and System output signal(s). The user must supply these cable assemblies. Refer to the System wiring diagram for details about interconnection.

This Page is Intentionally Blank

3. SPECIFICATIONS

Table 3.1

LKAT² OEM EMC System Specifications (subject to change without notice)

MAIN ANALOG SIGNAL OUTPUT															
Main Output Full-Scale Measuring Range	±5kA to ±150kA (Contact factory for full-scale measuring ranges > 100kA)														
Signal Output Type (configurable) mA output max. burden : 10V mA output max. loop/load resistance : 500Ω V output min. load resistance : 100kΩ	<table border="0"> <tr> <td>Zero kA</td> <td>± Full-scale kA</td> </tr> <tr> <td>0mA</td> <td>±20mA max.</td> </tr> <tr> <td>4mA</td> <td>+20 & -12mA</td> </tr> <tr> <td>0V</td> <td>±1V</td> </tr> <tr> <td>0.2V</td> <td>-0.6V to +1V</td> </tr> <tr> <td>0V</td> <td>±10V</td> </tr> <tr> <td>2V</td> <td>-6V to +10V</td> </tr> </table>	Zero kA	± Full-scale kA	0mA	±20mA max.	4mA	+20 & -12mA	0V	±1V	0.2V	-0.6V to +1V	0V	±10V	2V	-6V to +10V
Zero kA	± Full-scale kA														
0mA	±20mA max.														
4mA	+20 & -12mA														
0V	±1V														
0.2V	-0.6V to +1V														
0V	±10V														
2V	-6V to +10V														
Signal Output Calibration Accuracy *	±0.25% full-scale														
Linearity Error *	±0.1% of full-scale														
Repeatability Error Limits *	±0.1% of full-scale														
EMC immunity influence	< -0% FS to +0.25% FS (typical); -0% FS to < +3.6% FS (maximum)														
Response Time (t _d) *	≤ 100 μs														
di/dt Accurately Followed *	500 A/μs														
Frequency Response *	Switch selectable low-pass filter : No filter / 330hz / 660hz (refer to Figure 3.1 for additional info.)														
Temperature Sensitivity	±50ppm/°C or better														
Mains Voltage Sensitivity	±0.001%/V														
* At DynAmp reference conditions: Ambient 25°C ± 2°C (77°F ± 4°F) / Mains 120/240V AC RMS, 60Hz ± 1Hz															
MAIN STATUS INDICATORS															
Accuracy Diagnostics	Indicates LKAT ² System proper operation or operational problem														
Accuracy Diagnostics Status LEDs	Green LED indicates proper operation Red LED indicates operational problem														
Accuracy Diagnostics Status Relay Function	Relay coil de-energizes when operational problem detected or mains power lost.														
Over / Reverse Current Trip Setpoint Qty. (1)	Factory/field configurable to trip on either over current (+5%...+100% of full-scale) or reverse current (-5%...-100% of full-scale). Setpoint accuracy ±2%														
Over / Reverse Current Status LEDs	Green indicates operation OK – No Trip Red indicates measured current exceeds Trip Setpoint														
Over / Reverse Current Status Relay	Relay coil de-energizes when measured current exceeds Trip Setpoint or mains power lost.														
All Relay Function	Form C : Normally Open and Normally Closed Contacts (non-latching)														
All Relay Contact Ratings	120/250 VAC : 8A 30 VDC : 8A Relay response time 10mS typical														

Table 3.1
LKAT² OEM EMC System Specifications (subject to change without notice), continued

OPTIONAL PROTECTION EXTENSIONS (PE)	
PE Full Scale Measuring Range (<i>scaled independently and isolated from main output</i>)	±5kA to ±200kA (<i>Contact factory for full-scale measuring ranges > 100kA</i>)
PE analog output configuration and performance specifications	Same as Main output above with all configuration and scaling independent from main output
PE Over / Reverse Current Trip Setpoints -Qty. (2) - Field configurable	Function and specification same as Main Over / Reverse above with independent LEDs, configurations, scalings and outputs
OPTIONAL DISPLAY	
Digital Display of Bus Current in kA units	3 ½ Digit Green LCD ±2% Full-scale
Displayed Value (configurable)	DC or True RMS
NOTE: Optional display reduces maximum ambient temperature of Metering Unit to 50°C	
GENERAL	
Input Power (<i>any voltage within the specified range can be connected without any wiring changes</i>)	100-240Vac, 110-264 Vdc, 50-60Hz
Burden on Mains (max)	30 VA
Working Voltage: Signal Output to Metering Unit Low Voltage Circuit	450Vrms
Working Voltage: Bus to Metering Unit Low Voltage Circuit	1500Vdc
Working Voltage: Mains Supply to Metering Unit Low Voltage Circuit	264Vrms
Working Voltage: Mains Supply to chassis	264Vrms
Working Voltage: Output to chassis	450Vrms
Isolation : Measuring Head surface to signal outputs	6000Vrms for 1 minute
Isolation : Mains supply to signal outputs	1000Vrms for 1 minute
Isolation : Mains or signal output to chassis	2000Vrms for 1minute
Installation Category	II
Pollution Degree	2
ENVIRONMENTAL	
Operating Ambient Temperature Range of Metering Unit Location	-10°C to 60°C (14°F to 140°F)
Operating Ambient Temperature Range of Measuring Head	-20°C to 80°C (-4°F to 176°F)
Environmental rating: Measuring Head and cable connection at Measuring Head	IP65
Environmental rating: Metering Unit and cable connection at Metering Unit	IP10

Table 3.1
LKAT² OEM EMC System Specifications (subject to change without notice), continued

PHYSICAL	
Measuring Head Weight	Typically 1 to 6 kg (3 to 13lbs.)
Metering Unit Weight (Typical)	Typically 3kg (7lbs.)
Standard Length Measuring Head Connection Cables (2) Optional custom lengths may be available up to 50m (164 ft.)	10m (33 ft.) Cable fixed to Measuring Head
Standard Length Signal Output Cable (1) Optional custom lengths are available	Not supplied with OEM EMC System
Standard Length Power Input Cable (1) Custom lengths are available	Not supplied with OEM EMC System

Figure 3.1
LKAT² Frequency Response
Normalized LKAT Bandwidth

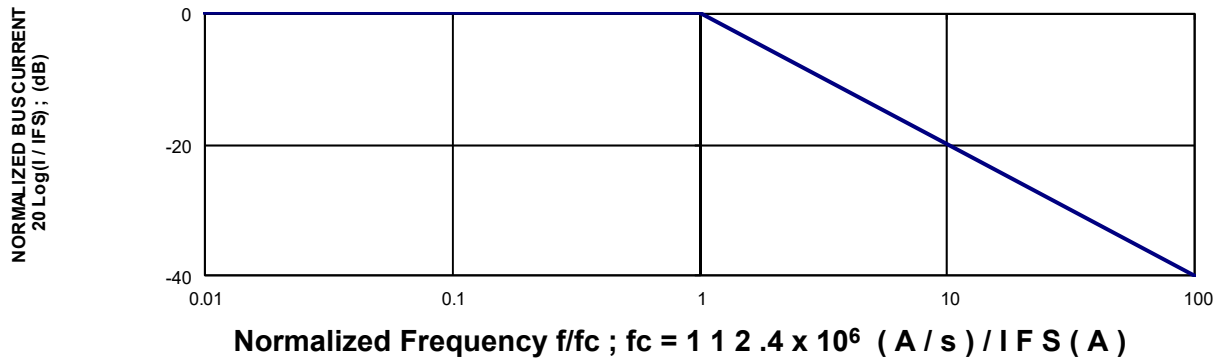

F.S. Bus Current (kA)	5 to 50	60	70	80	90	100
Corner Frequency (kHz)	2.248	1.873	1.606	1.405	1.249	1.124

This Page is Intentionally Blank

4. INSTALLATION

4.1 HANDLING PRECAUTIONS

LKAT² Systems should be handled with the same care as any precision measuring instrument. Severe jolts or bumps to the Measuring Head or Metering Unit may cause movement of internal parts, and possibly a malfunction. **Personnel involved in the installation should be familiar with the technical terms, warnings, and instructions in this manual, and all plant safety rules, and be able to follow these regulations.**

The complete system should be inspected for shipping damage at the earliest opportunity. Visible damage must be reported to the carrier immediately. Concealed damage (not evident until the system is operated) must be reported to DynAmp, LLC immediately.

4.2 INSTALLATION CONSIDERATIONS

Read the following before mounting the Measuring Head:

1. The Measuring Head is designed to be installed on high voltage bus bars. All interconnection cables must be safely routed away from bus bars and high voltages. Do not allow any interconnection cable to contact bus bars or high voltages. Ignoring the installation precautions and warnings can result in severe personal injury or equipment damage.
2. Always follow all local and plant safety procedures when the unit is to be installed on a live bus.
3. Choose a mounting location for the Measuring Head where the ambient air temperature does not exceed the specified temperature limits. The LKAT² Measuring Head may be located indoors or outdoors, but should be kept away from extreme heat and solvents. Measuring Head installations in direct sunlight are not recommended, as excessive temperature rise could result in measurement error or damage to the Measuring Head enclosure. If the Measuring Head is to be installed in an especially harsh environment, please contact the factory to discuss special requirements.
4. No part of the Measuring Head or Metering Unit should be submerged under water.
5. The Measuring Head must be installed with proper polarity. An arrow indicates the direction that conventional bus current must flow through the aperture (+) to (-). No damage will occur if the Measuring Head is reversed, but the system output will indicate current flow in the reverse direction.
6. Measuring Heads are shipped in matched halves. Make sure that the same serial number is present on both halves of the Measuring Head and the Metering Unit. The two Measuring Head halves should mate squarely and evenly without forcing or twisting.
7. The Measuring Head is not grounded; however, the Measuring Head cables should be disconnected from the Metering Unit prior to installation or maintenance to minimize the possibility of electrical shock.
8. Measuring Heads are shipped with mounting hardware. The mounting screws may require adjustment for appropriate position and holding force on the bus. Refer to Outline & Mounting – LKAT² Measuring Head drawing.

Whenever possible, the Measuring Head should be installed on the longest straight run of the bus that is available in an area free of other bus structures. The status accuracy diagnostics LEDs and relay contacts indicate proper operation in a given Measuring Head location.

4.3 OFF-BUS FUNCTIONAL CHECK (OPTIONAL)

After unpacking the LKAT² System (but prior to installation), the following functional check of the system is recommended:

1. Locate a convenient temporary power source for the LKAT² System. This may or may not be in the location where the system will be installed. The power source must be in the range 85 to 264Vac @ 47 to 440Hz, or 110 to 264Vdc for standard AC/DC input power, or +24Vdc for Special Order +24Vdc input power. The system draws a maximum of 30 volt-amperes.
2. Refer to the drawing “Wiring Diagram, LKAT² System” included at the end of this manual. Attach a suitable connector to the unterminated end of the input power cable assembly for connection to the power source to be used for this check.
3. Connect the Measuring Head cables A & B to the Metering Unit.
4. Connect the power input cable assembly to the Metering Unit and energize the unit.
5. Observe the LEDs on the Main pc board assembly. If the LEDs light green, the system is functioning properly. If LED (Accuracy Diagnostics “AD”) lights red, skip to “Troubleshooting an Accuracy Diagnostics Fault Indication” in the “Theory of Operation” section of this manual. If LED (Trip 1) lights red, make measurements and complete the form “LKAT² Diagnostic Measurements Form – Zero Primary Current” and contact the factory.

Refer to Form 1 – LKAT² Diagnostic Measurements Form - Zero Primary Current. Allow the system one hour to stabilize prior to making measurements. Make measurements and record data shown on the form. File the completed test form for future reference. It is OK to make these measurements away from location where the LKAT² System will be installed, but this should be noted on the form.

4.4 MEASURING HEAD INSTALLATION

The Measuring Head halves are mated together around the bus. The Measuring Head is comprised of two “L” shaped halves. Each half is identified with a serial number which must match followed by an “A” or “B”. One interconnection cable exits from each corner box on each half. The two halves are held together by four locking screws which are installed after the Measuring Head is securely positioned around the bus bar.

When the Measuring Head is installed on a running (“horizontal”) bus, the Measuring Head interconnection cable assemblies should exit the corner enclosures on bottom side of the bus bar. This reduces chances of ingress by pollutants and minimizes heating of the Measuring Head electronics by the bus.

For rising (“vertical”) busses, the Measuring Head interconnection cables may be located on any side of the bus, depending on mechanical and thermal considerations. Avoid mounting elbows with cable assemblies above vertical bus. The Measuring Head should be mounted on the bus bar so conventional (+) to (-) current flows in the direction of the arrow on the Measuring Head.

The following tools and materials may be required for installation:

3/16” hex wrench (included with Measuring Head)
Drill, drill bits, mounting hardware, screwdrivers, wrenches, etc.
Cable puller, cable ties, ladder, etc.

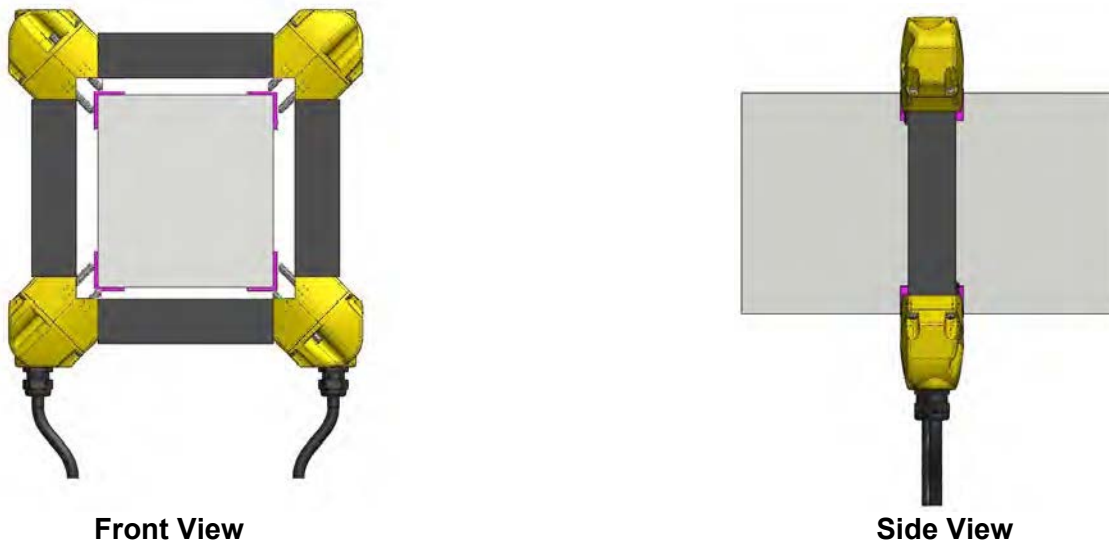

Figure 4.1
Installation Configuration

Refer to drawings “Outline and Mounting LKAT² Measuring Head” and “LKAT² Head Mounting Methods & Reference Dimensions” at the end of this manual.

For Measuring Heads with “P” dimension **greater than 90mm**, the following steps are recommended sequence for installing the Measuring Head:

1. Determine the position where the Measuring Head will be installed. Bus bar(s) should be free from grease and dust for the best adhesion of the LKAT² 90° fiberglass mounting angles to the bus bar(s).
2. Connect the head cable assemblies to the Metering Unit.
3. Remove the backing from the adhesive foam strips on the fiberglass mounting angles. Position the mounting angles in position on the corners of the bus bar in the desired location.
4. Position the two “L-shaped” Measuring Head halves around the bus and the mounting angles, (if used). Mate the two halves, pressing them together until the tubes bottom out on the elbows.
5. Install the four locking screws on the outside of the square tubes adjacent to the place where the Measuring Head halves split apart. Do not over tighten the locking screws. Refer to Outline & Mounting – LKAT² Measuring Head drawing.
6. Tighten the bus mounting screws a few turns at a time in a circular pattern around the aperture of the Measuring Head, on the front side, then on back side of the Measuring Head. For most applications, the Measuring Head should be centered on the bus bar. The bus mounting screws should press against the foam tape on the mounting angle surface on the outside of the bus bar. Refer to Outline & Mounting – LKAT² Measuring Head drawing. Do not overtighten bus mounting screws.
7. Route the Measuring Head interconnection cables away from the bus and other high voltages.

For Measuring Heads with “P” dimension of **60mm and/or 90mm**, the following steps are recommended sequence for installing the Measuring Head:

1. Determine the position where the Measuring Head will be installed. Bus bar(s) should be free from grease and dust.
2. Install mounting screws in each of the threaded inserts in the Measuring Head (2 places per elbow). Turn screws clockwise such that about ½” (12.7mm) of the screw protrudes inside the elbow aperture.
3. Install one PEEK plastic cap nut on each mounting screw. (8 places total).
4. Position the two “L-shaped” Measuring Head halves around the bus. Mate the two halves pressing them together until the tubes bottom out on the elbows.
5. Install the four locking screws on the outside of the square tubes adjacent to the place where the Measuring Head halves split apart. Do not over tighten the locking screws. Refer to “Outline & Mounting - LKAT² Measuring Head” drawing.
6. Tighten the bus mounting screws a few turns at a time in a circular pattern around the aperture of the Measuring Head, on the front side, then on back side of the Measuring Head. For most applications, the Measuring Head should be centered on the bus bar. The PEEK cap nuts should press against the outside of the bus bar. Do not overtighten bus mounting screws.
7. Route the Measuring Head interconnection cables away from the bus and other high voltages.

4.5 METERING UNIT INSTALLATION

The location of the Metering Unit should be determined by the following factors:

1. Ambient air temperature must stay in the specified range at all times.
2. The location should not be exposed to direct sunlight.
3. The location should be within reach of the Measuring Head cables supplied with the system. Standard Measuring Head cable length is 33 feet (10 meters). Extra-long Measuring Head cables may also be ordered for special applications.
4. Route interconnection cables away from bus and other high voltages.

Refer to Metering Unit Outline & Mounting drawing at the end of this manual. Anchor the cabinet in the desired location after ensuring adequate cable reach.

5. Connect Measuring Head cable assemblies to the Metering Unit.
6. Refer to the LKAT² OEM EMC System Wiring Diagram. Connection to the input power is made via TB2 mounted on the LKAT² OEM EMC panel. Use of 18 AWG (or larger) type SJT (or equivalent) cable for input power wiring.
7. The output requires up to 8 conductors for the main pc board assembly and up to 8 conductors for the optional PE PCB assembly. These cables must be connected to the TB3 on the system panel. Use of 20AWG twisted pair cable (4 or 8 pairs) is recommended.

4.6 SYSTEM CHECKOUT

Recheck all wiring connections against the drawings to ensure proper installation. Energize the LKAT² System. Confirm that the green status LEDs are illuminated. If accuracy diagnostic LED lights red, skip to “Troubleshooting an Accuracy Diagnostics Fault Indication” in the “Theory of Operation” section of this manual

Energize the rectifier to the desired test current. Calculate the expected Metering Unit output signal magnitude at the test current. The measured Metering Unit output signal magnitude digital display (optional) should be equal to (or very close to) the expected value that was calculated.

If the Digital Display option is included in the Metering Unit, the displayed kA level should also be equal to (or very close to) the expected value that was calculated.

Refer to “Specifications” section of this manual for more information.

Photocopy the appropriate LKAT² Diagnostic Measurements Forms. Form 1 is for diagnostic measurements at zero bus current (with the Measuring Head on or off the bus). Form 2 is for diagnostic measurements with the Measuring Head installed on the bus with the bus energized. Follow the directions to measure and record necessary information.

NOTE :

- These forms are intended to help keep accurate records of LKAT² functional tests.
- This information may prove valuable in the event of a malfunction.
- These measurements do not constitute system calibration.
- Space is provided for the recording of three sets of readings.
- Voltages may vary slightly with temperature extremes.
- System performance will typically remain within nominal specifications when measured levels fall within the acceptable limits shown on the forms.
- Levels must be measured and recorded under test conditions shown on the forms.
- The Metering Unit cover must be open during system checkout, as all measurements are made inside the Metering Unit on the Main pc board terminal blocks. The cover should remain firmly closed during normal operation.

Always complete these forms in full **before** contacting the factory.

Form 1 LKAT² Diagnostic Measurements Form – Zero Primary Current

Instructions:

- 1.) Ensure that the Metering Unit is energized and both Measuring Head halves are mated and connected to the Metering Unit.
- 2.) Ensure that Measuring Head is off bus, or that bus is de-energized.
- 3.) Measure and record the information below (make additional copies of this form as needed).
- 4.) Record Serial Numbers.

TEST CONDITIONS:

**ZERO PRIMARY CURRENT (Measuring Head may or may not be installed on bus);
LKAT² SYSTEM must be ENERGIZED for AT LEAST ONE HOUR.**

MEASURE	(+) DMM at	(-) DMM at	ACCEPTABLE RANGE	DATE ___/___/___	DATE ___/___/___	DATE ___/___/___
+V _{Hall} Supply-A	P4-1	P4-3	+12V (±0.5V)			
+V _{Hall} Supply-A	P4-2	P4-3	+12V (±0.5V)			
+15V supply	P4-4	P4-5	+15V (±0.5V)			
-15V supply	P4-6	P4-5	-15V (±0.5V)			
Input A1	P1-1	P1-2	0V (±5mV)			
Input A2	P1-3	P1-2	0V (±5mV)			
Input B1	P2-1	P2-2	0V (±5mV)			
Input B2	P2-3	P2-2	0V (±5mV)			
Output Current Loop Burden at Full-Scale	P3-1	P3-2	10.2V max			

Serial Numbers :

Metering Unit _____

Measuring Head -

A half _____ B half _____

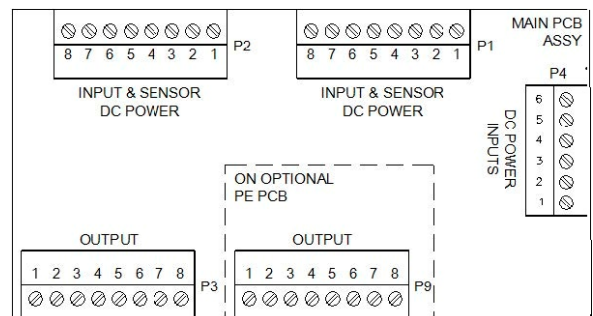

Form 2

LKAT² Diagnostic Measurements Form – Energized Primary Bus

Instructions:

- 1.) Ensure that the Metering Unit is energized and both Measuring Head halves are mated and connected to the Metering Unit.
- 2.) Ensure that Measuring Head is on bus and that bus is energized.
- 3.) Measure and record the information below (make additional copies of this form as needed).
- 4.) Record Serial Numbers and Current Loop Burden Resistance (Ohms).

**TEST CONDITIONS:
ENERGIZED PRIMARY BUS;**

LKAT² SYSTEM must be ENERGIZED for AT LEAST ONE HOUR.

MEASURE	(+) DMM at	(-) DMM at	ACCEPTABLE RANGE	DATE ___/___/___	DATE ___/___/___	DATE ___/___/___
+V _{Hall} Supply-A	P4-1	P4-3	+12V (±0.5V)			
+V _{Hall} Supply-A	P4-2	P4-3	+12V (±0.5V)			
+15V supply	P4-4	P4-5	+15V (±0.5V)			
-15V supply	P4-6	P4-5	-15V (±0.5V)			
Input A1	P1-1	P1-2	Within ±25mV of Input A2			
Input A2	P1-3	P1-2	Within ±25mV of Input A1			
Input B1	P2-1	P2-2	Within ±25mV of Input B2			
Input B2	P2-3	P2-2	Within ±25mV of Input B1			
Output Current Loop Burden at Full-Scale	P3-1	P3-2	10.2V max			

Serial Numbers :

Metering Unit _____
 Measuring Head -
 A half _____ B half _____
 Nominal Current Loop Burden Resistance (Ohms) _____

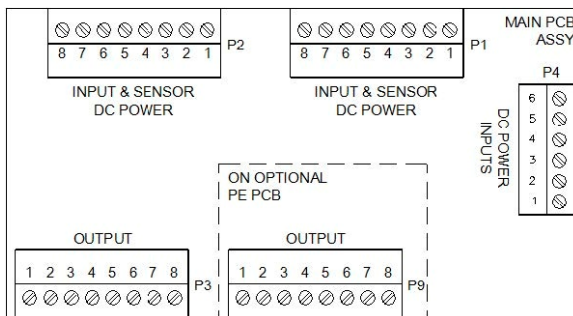

This Page is Intentionally Blank

5. THEORY OF OPERATION

5.1 GENERAL

The LKAT² System uses open-loop, open-path (OLOP) technology to convert the magnetic field associated with a current carrying conductor into an isolated milliamperere current loop output. This output is scaled to be proportional to the primary conductor current. In addition, a local digital display of the primary bus current (in kiloAmperes) is visible when the optional RMS Display pc board is added to Metering Unit.

Each Measuring Head is a sealed unit and is not designed for repair in the field. However, a working knowledge of the LKAT² System theory of operation will help facilitate timely and accurate diagnosis in the event of problems.

5.2 OLOP TECHNOLOGY

The term “open-loop” means that the magnetic circuit does not generate an opposing magnetic field to null the field produced by the primary conductor inside the Measuring Head. The term “open-path” indicates that the sensor is an air-core design, without magnetic core material.

The LKAT² System operation is based on Ampere’s Law, which states: “the line integral of B (magnetic flux density) around any closed path is equal to $\mu_0 I$ (permeability multiplied by current)”. In practical terms, this means that integrating a closed path around a primary conductor will yield a value proportional to the net primary current.

This integration is implemented using a specific array of Hall Effect ICs. The LKAT² System effectively minimizes errors typically present in other open-loop sensors: zero drift, thermal drift, position sensitivity, and susceptibility to external magnetic fields. The absence of a magnetic core practically eliminates errors due to saturation, hysteresis, and core set (remanence) commonly associated with ferrite material.

A generalized block diagram of the LKAT² System is shown in Figure 5.1.

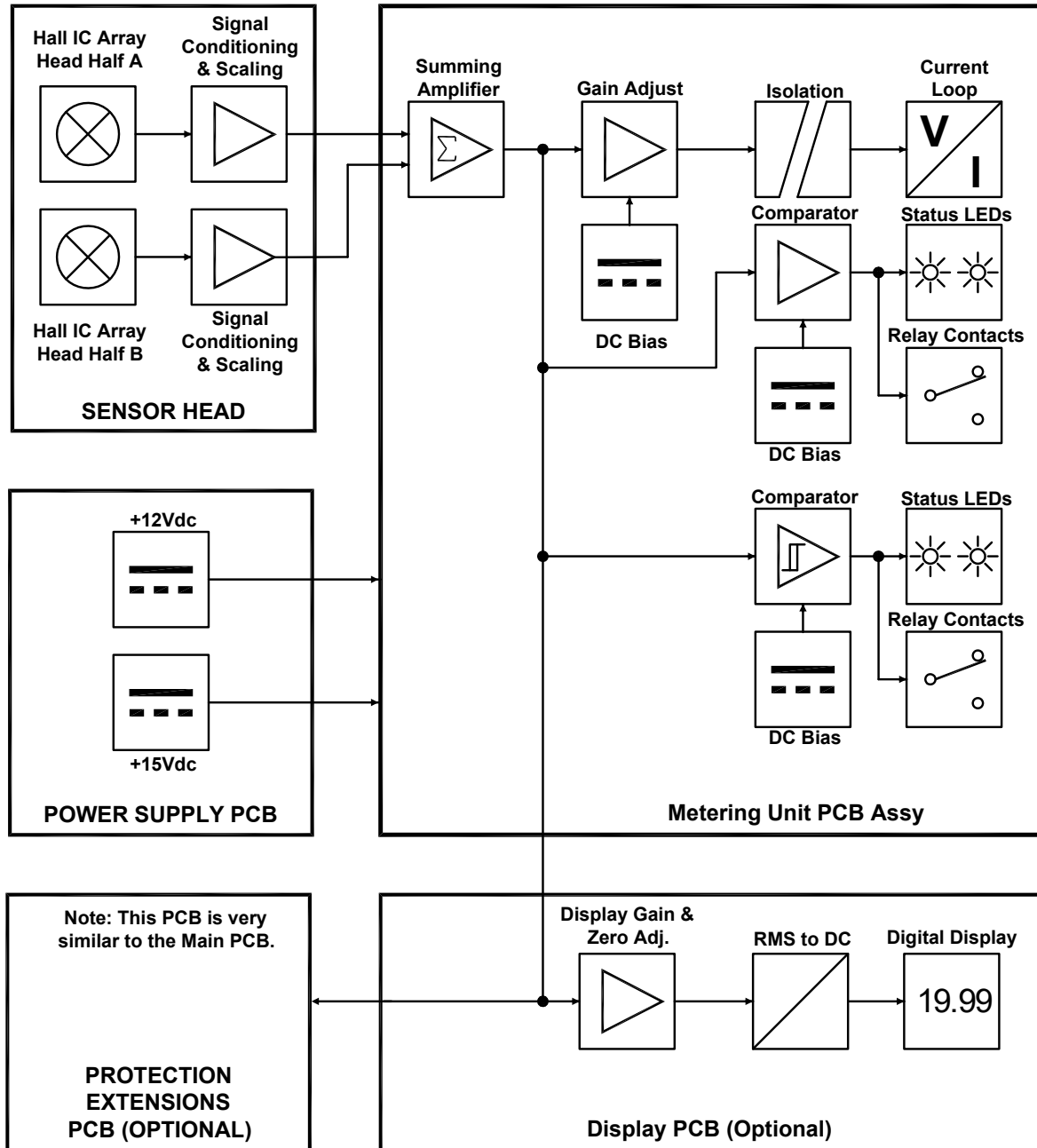

Figure 5.1
Block Diagram of the LKAT² System

5.3 SYSTEM FUNCTIONAL DESCRIPTION

The flux density associated with the primary current is sensed by arrays of Hall ICs in the Measuring Head. The outputs of these devices are summed and filtered, then transmitted to the Metering Unit where these signals are dc biased and scaled. The Accuracy Diagnostics status LEDs and relay contacts are driven by a signal input that compares the various Hall groups with voltage setpoints. When the Hall group signal exceeds the reference, the green

LED will go out and the red LED will illuminate. The relay coil will change state under the same conditions. The Trip Setpoint LEDs and relay contacts operate in a similar manner.

Main PCB LED is a RED / GREEN the Accuracy Diagnostics status LED. This LED indicator and Main PCB relay CR2 contacts may be used to monitor the following conditions:

- Measuring Head imbalance
- Power supply failure
- Measuring Head disconnected
- Sensor electronics failure
- Other circuit failures causing loss of measurement accuracy

Occurrence of one or more of the conditions above will change the state of the CR2 relay coil, changing the state of the contacts and changing the LED indication from green to red. Refer to the section “Troubleshooting an Accuracy Diagnostics Fault Indication” in this chapter for more information about determining the cause and eliminating a fault condition.

Refer to section “Failsafe” / “Non-Failsafe” Configuration in this chapter for more information about Alarm Relays.

5.4 LKAT² METERING UNIT

Refer to drawings in the back of this manual.

Input power connects to the Power Supply pc board assembly. The power supply pc board includes a non-replaceable slo-blo type fuse, in-rush and overcurrent protection, as well as overvoltage clamping. The power supply provides outputs of $\pm 15\text{Vdc}$ and $+12\text{Vdc}$ required by the system electronics. These outputs connect to the Main pc board assembly via a short wire harness.

Connections to the Measuring Head are made via the Main pc board assembly.

5.5 LKAT² MEASURING HEAD INTERCHANGEABILITY

DO NOT connect LKAT Classic or LKAT Plus Measuring Heads to a LKAT² Metering Unit – doing so will damage them.

LKAT² Measuring Heads of various sizes will operate properly when connected to the LKAT² Metering Unit. However, the LKAT² System is **factory calibrated as a system**. As a result, optimal measurement accuracy is achieved when the Metering Unit is connected to the Measuring Head it was calibrated with, and installed on the size bus bar it was designed for.

5.6 TROUBLESHOOTING AN ACCURACY DIAGNOSTICS FAULT INDICATION

A problem may be detected when the LKAT² System is energized with A and B Measuring Head cables connected to the Metering Unit. When the Main PCB AD status LED illuminates RED and / or Main PCB CR2 status relay coil changes state, a possible fault condition has been detected. This is true whether or not the Measuring Head is installed on the bus. The following table is intended to help the user determine and eliminate the cause of the fault.

Table 5.1
Troubleshooting an Accuracy Diagnostics Fault Indication

Main Green LED	Main Red LED	Contact P3-3 to P3-5	BUS ON	BUS OFF	Possible problem	Action / Check
ON	OFF	Open	X	X	System operating properly	DC measurements (optional)
OFF	OFF	Closed	X	X	No input power	Verify input power connection
OFF	OFF	Closed	X	X	DC power supply problem	Verify DC power on main PCB
OFF	ON	Closed	X	X	Measuring Head halves disconnected	Verify Measuring Head interconnections at Metering Unit
OFF	ON	Closed	X		Measuring Head imbalance	Adjust position of Measuring Head for green ON, red OFF
OFF	ON	Closed	X	X	Measuring Head malfunction	Measure head input signals at zero bus current; output should be < 5mVdc; substitute known good Measuring Head
OFF	ON	Closed	X	X	Other problem	Contact factory

5.7 SYSTEM CALIBRATION OVERVIEW

DynAmp does not specify exact required intervals of calibration for its products.

The end user of the product is responsible for identifying the appropriate interval between calibrations. The intervals should be determined based on the following factors:

- Requirements of a Quality Management System
- Accuracy and permissible limits of errors
- Purpose and usage
- Experience with similar products
- Manufacturer's recommendations
- Stability of the product
- Past history
- Other characteristics of the product

Reference: "ISO/IEC 17025:2017, General requirements for the competence of testing and calibration laboratories" and Laboratory Accreditation Bureau "Guidance for Documenting and Implementing ISO/IEC 17025:2017 and Laboratory Guidance."

As a guideline, DynAmp recommends a 24-month interval of calibration for all permanently installed products and a 12-month interval of calibration for all products used in portable applications.

Calibration may be performed as:

- Field Calibration (On Process Bus)
- Field Calibration (On Test Bus)
- Factory Calibration

IMPORTANT NOTE

DynAmp, LLC assumes no responsibility for the accuracy of LKAT² Systems calibrated by any person other than a DynAmp, LLC Technician.

Generally, system calibration compares the output of the device under test (“DUT”) to a reference.

The best calibration method is to return LKAT² Systems to the factory for calibration on a test bus in a very controlled environment with extremely stable and accurately measured current. This requires that the LKAT² Measuring Head be removed from process bus. The Measuring Head and associated Metering Unit must be returned together, and should have the same serial number. The signal output and input power cable assemblies do not need to be returned for factory calibration. Specific details of factory calibration are beyond the scope of this manual.

Field calibration is possible using a 0.1% accurate current measurement system, such as the DynAmp LKP, LKCO or Opti-Cal as a reference. Due to significantly larger size and mass, it may be difficult to install a comparably rated LKP Measuring Head on the same bus as the LKAT². An existing LKCO or DynAmp’s portable Opti-Cal system is better suited for this purpose.

Field calibration accuracy depends on the stability of the test bus current, the accuracy of the reference current measurement system and ammeters, as well as the linearity of the LKAT² System.

5.8 CALIBRATION ADJUSTMENTS

IMPORTANT NOTE

To avoid injury and/or electrical shock, personnel performing calibration must review and observe all hazard warnings and safety precautions stated throughout this product manual.

LKAT² System calibration adjustments are summarized below.

All Bias and Zero adjustments are made at zero bus current.

All Scaling and Gain adjustments are typically made at full-scale current.

Refer to pc board assembly drawings at the end of this manual for location of switches and potentiometers, as well as tables listing proper switch settings. Except for step 1) below, each table is shown on the appropriate pc board assembly drawing.

Forms 1 and 2 are used to check and record system power supply and channel voltages.

Main PCB – Current Loop Output

- Output Bias (coarse) : SW2C...SW2F
- Output Type : SW6
- Output Gain (coarse) : SW3
- Output Bias (fine) : Trimpot
- Output Gain (fine): Trimpot

Main PCB – Trip 1 Setpoint

- Trip 1 Protection Polarity : SW2A and SW2B
- Trip 1 Setpoint : Trimpots (medium) and (fine)

Optional PE PCB – Current Loop Output

- Output Bias (coarse) : SW4
- Output Type : SW5
- Output Gain (coarse) : SW1 and SW2
- Output Bias (fine) : Trimpot
- Output Gain (fine) : Trimpot

Optional PE PCB – Trip 2 & 3 Setpoints

- Trip 2 Protection Polarity : SW3
- Trip 2 Setpoint : R33 (medium) and R46 (fine)
- Trip 3 Protection Polarity : SW3
- Trip 3 Setpoint : R34 (medium) and R47 (fine)

Optional RMS Display PCB – Display

- Decimal Point position
- DPM Mode
- RMS Signal Conditioning Options : SW1F, G, & H (SW1-6, 7, & 8)
- Input Scale Factor : SW1E (SW1-5)
- Input Attenuation : SW1A, B, C, & D (SW1-1, 2, 3, & 4)
- DPM Gain (fine) : R12

NOTE

The Optional PE and/or RMS Display pc board assemblies may be added, configured and calibrated in the field. In this case, the Main pc board assembly output signal is used as the reference output signal with the LKAT² System measuring normal bus current.

5.9 FIELD CONFIGURATION OF TRIP SETPOINTS

Trip setpoints may be re-configured on site for any level between 5% and 100% of full-scale. The trip polarity may also be re-configured on site. However, the Accuracy Diagnostics trip setpoint should not be adjusted without consulting the factory.

Refer to assembly drawings for the Main pc board and PE pc board (optional) included at the end of this manual. To change trip polarity adjust SW2A and SW2B according to the table on the assembly drawing.

The trip setpoint is proportional to the current where the trip will occur: “Trip Current” – from Metering Unit nameplate.

The easiest method to check or change trip setpoints is to use the DynAmp LKAT MUT system which is specifically designed to simplify this process as well as verify proper operation afterwards.

To configure the trip setpoint without the LKAT MUT or complete test stand, the following method can be used.

Refer to Table 5.2, “Trip Configuration Details”. Measure the existing setpoint voltage (V_{STPT}); use the equation below to calculate the new setpoint voltage. Adjust coarse and fine potentiometers to produce calculated New V_{STPT} .

$\text{New } V_{STPT} = \frac{\text{New Trip Current}}{\text{Old Trip Current}} \times \text{Old } V_{STPT}$									
<p>Example:</p> <table style="margin-left: 20px;"> <tr> <td>Old V_{STPT}</td> <td>=</td> <td>7V</td> </tr> <tr> <td>Old Trip Current</td> <td>=</td> <td>70kA</td> </tr> <tr> <td>New Trip Current</td> <td>=</td> <td>80kA</td> </tr> </table>	Old V_{STPT}	=	7V	Old Trip Current	=	70kA	New Trip Current	=	80kA
Old V_{STPT}	=	7V							
Old Trip Current	=	70kA							
New Trip Current	=	80kA							
$\frac{80kA}{70kA} \times 7V = 8V \text{ (New } V_{STPT}\text{)}$									

**Table 5.2
Trip Configuration Details**

Trip Circuit	V _{STPT} Location	Medium Adjust Trimpot	Fine Adjust Trimpot
1 (Main)	TP6 (Main)	R91	R98
2 (PE)*	TP2 (PE)*	R33	R46
3 (PE)*	TP3 (PE)*	R34	R47
Use TP0 for zero volt reference (circuit common) for voltage measurements for trip setpoint configuration.			

* Optional

NOTE

The LKAT² is supplied with factory configured trip setpoints configured as specified in the LKAT² Worksheet at the time of order. If the trip setpoints are reconfigured in the field, the customer must realize that the trip setpoints shown on the LKAT² Metering Unit nameplate will no longer be correct. In this case, DynAmp suggests that the nameplate be changed to reflect the new trip setpoint (following reconfiguration).

5.10 EARTH GROUNDING

Here is a detailed description of the Earth Ground connection path:

1. The input power cable assembly connects TB2 to the mains power.
2. Refer to the LKAT² OEM EMC System Wiring Diagram and wire system accordingly.
3. The earth ground wire connects from TB2 to the FLTR1 metal case only. The FLTR1 metal enclosure is not connected to copper foil traces on the Power Supply PC board assembly, the steel standoff inserts or the steel PCB mounting bracket.
4. The Earth Ground connection is only used to shunt common mode noise to earth.

IMPORTANT NOTE
There is no electrical connection from any part of the LKAT ² Main PCB or its optional daughter PCBs to Earth / Chassis ground or the steel PCB mounting bracket or panel. There is no electrical connection between the steel PCB mounting bracket or panel to Earth Ground.

5.11 CONFIGURING THE LOW PASS FILTER

The LKAT² System includes a two pole configurable low pass filter. This filter may be enabled without affecting the scaling of the output in the pass band. The frequency response of the LKAT² without the low pass filter activated is shown in Figure 3.1.

Refer to the Main pc board assembly drawing at the end this manual.

5.12 “FAILSAFE” / “NON-FAILSAFE” CONFIGURATION

The LKAT² System relay outputs are failsafe as factory configured. When the system is energized, all relay coils are energized and all contacts change state; that is, open contacts close and closed contacts open. During any alarm condition, relay coils de-energize, which changes the state of the relay contacts.

In the failsafe configuration, loss of input power to the LKAT² Metering Unit de-energizes the alarm relay coils. This causes the relay contacts to change state and indicate an alarm condition. For some applications, the user requires that Trip1 to be “non-failsafe”. That is, the system should not produce an alarm when there is loss of input power. Alarm conditions other than loss of input power must continue to result in an alarm. Trip1 relay contacts can be configured for Non-Failsafe operation. AD relay contacts are failsafe only. Trip2 and Trip3 relay contacts (present on optional PE PCB assembly) are failsafe only.

Table 5.3 shows the status of the LKAT² alarm relay contacts. The alarm relay contact condition is shown as it exists at the customer connections to the metering unit.

To convert the LKAT² System Trip1 to non-failsafe operation requires modification of the Main pc board assembly. Contact factory.

Table 5.3
LKAT² Alarm Relay Status
(As found at Customer Connection to Metering Unit)

Non-Failsafe Metering Unit Configuration				
Alarm Name	Contact Set	POWER OFF	POWER ON NORMAL	POWER ON ALARM TRIPPED
Trip2	P9-6 to P9-8	Closed	Open	Closed
	P9-6 to P9-7	Open	Closed	Open
Trip3	P9-3 to P9-5	Closed	Open	Closed
	P9-3 to P9-4	Open	Closed	Open
Trip1	P3-6 to P3-8	Open	Open	Closed
	P3-6 to P3-7	Closed	Closed	Open
AD	P3-3 to P3-5	Closed	Open	Closed
	P3-3 to P3-4	Open	Closed	Open

6. MAINTENANCE & SPARE PARTS

6.1 PERIODIC MAINTENANCE

As is true with any electronic system, proper maintenance will tend to prolong the service life. DynAmp, LLC recommends the following program be performed at the recommended interval to prevent or detect damage to the LKAT² System and to ensure reliable performance. Always use appropriate measures to correct any problems found. Following the suggested maintenance schedule may assist in early diagnosis of problem(s) to minimize repairs and down time.

IMPORTANT NOTE:

If Main pc board LED (AD Status LED) is illuminated RED and / or the status relay coil de-energizes, a fault condition may exist in the LKAT² electronics. When this occurs, the system may require immediate attention. Refer to "Troubleshooting an Accuracy Diagnostics Fault Indication", in the "Theory of Operation" section of this manual.

6.2 ANNUAL MAINTENANCE

Refer to the "Calibration" section of this manual for calibration intervals.

If possible, perform the steps described in section titled "System Checkout" in the "Installation" section of this manual at least once per year to verify performance of the LKAT² System. This may help to prevent or detect damage to the system and to ensure reliable performance. Use appropriate measures to correct any problems found. If LKAT² System equipment is exposed to extreme temperatures, DynAmp, LLC recommends these steps be performed during the hottest time of the year.

In addition, the following steps should be performed once each year as part of annual maintenance:

1. Visually inspect Measuring Head and interconnection cable for evidence of severe overheating, cracks, separation of bonded surfaces, or excessive corrosion. Record any suspect conditions.
2. Inspect the Measuring Head mounting screws and adjust as needed.
3. Visually inspect Metering Unit for evidence of severe overheating, corrosion, or condensation. Record any suspect conditions and take appropriate action.
4. Clean as necessary; remove any oil or grease with a mild detergent. Do not use abrasives or strong chemical solvents as they may damage the cables or erase the silk-screen markings from the Metering Unit.
5. Disconnect power to the system before servicing.

CAUTION

To avoid the risk of shock and electrocution, always disconnect all cable assemblies before performing any cleaning on the Metering Unit.

6.3 SPARE PARTS

The following table lists the minimum recommended quantities for spare parts for the LKAT² System. As spares are used, replacements should be ordered. Since continuous operation of high-current measurement systems is often critical, stocking spare parts should be given high priority.

Some cable assemblies for the LKAT² System include circular connectors. Others use solder cup connectors assembled with adhesive-lined shrink tubing covering the connector shell. If connector(s) are severed from the associated cable assembly, field installable replacement connectors may be purchased. These connectors may also be installed after routing Measuring Head interconnection cables in conduit. Over-molded replacement cable assemblies may be purchased for the power input and output cables. Measuring Head cable connector(s) must be replaced by field installable type(s), or with a new Measuring Head. Refer to Spare Parts List Table 6.1.

The LKAT² System Measuring Heads require special repair procedures and materials. However, the Measuring Heads are very reliable and should require little or no repair over its service life. Please refer to the nearest authorized DynAmp, LLC service center for information on repairs.

Disconnect power to the system before servicing.

Table 6.1
Spare Parts List

DESCRIPTION	ITEM NO.	RECOMMENDED QUANTITY
Angle, LKAT ² Mounting 100mm	46039	8 (each)
Nut, Cap ¼-20 PEEK (for heads with "P" dimension <= 90mm)	47605	8 (each)
Screw , LKAT ² mounting SHCS 1/4-20 X 3"	46028	2 (each)

Spare System		
Complete System (Measuring Head & Metering Unit calibrated as system)	*	TBD
Metering Unit	**	TBD
Measuring Head	**	TBD

* Item number same as original system

** Contact DynAmp, LLC

7. DRAWINGS

**Table 7.1
Drawing List**

DRAWING TITLE	NUMBER	REVISION
Wiring Diagram: LKAT ² OEM System With EMC Filtering	83B109437	C
Assembly: LKAT ² Metering Unit Sigma/OEM w/ EMC Filtering	75B109591	-
Assembly: LKAT ² Main PCB With EMC Filtering	75A109442	A
Assembly: LKAT Protection Extensions PCB With EMC Filtering	75A109464	A
Assembly: LKAT RMS Display PCB	75A108588	C
Outline and Mounting: LKAT ² Measuring Head	02B109349	E
Outline and Mounting: LKAT ² OEM Metering Unit	02A109520	-
LKAT ² Head Mounting Angle Reference Dimensions	75B109499	A